

1. Introduction

Module **A-127** is a **Voltage-Controlled Triple Resonance Filter**, consisting of three separate **band pass filters** with one common **input**.

For each of the filters, the **filter frequency** and **Resonance can be manually controlled**, and in addition the filter frequency can be voltage controlled. Each filter has its own **audio output**. There is also a **Mix output** which takes your chosen amounts of each of the three filter outputs and the original signal - set by the Audio Level controls - and outputs them from one socket.

Each of the filters also has an **internal LFO** (a triangle waveform) for modulating the filter, and there are controls for **LFO frequency** and **amplitude**. Instead of the LFO, an **external control voltage** can be used, whose amplitude can be manually controlled.

H There is an alternative scenario:- each of the three filters can also be configured as a **12dB low-pass filter** with resonance control. To do this, a jumper has to be re-positioned on each of the three circuit boards (see chapter 7, Appendix).

2. VCRF - Overview

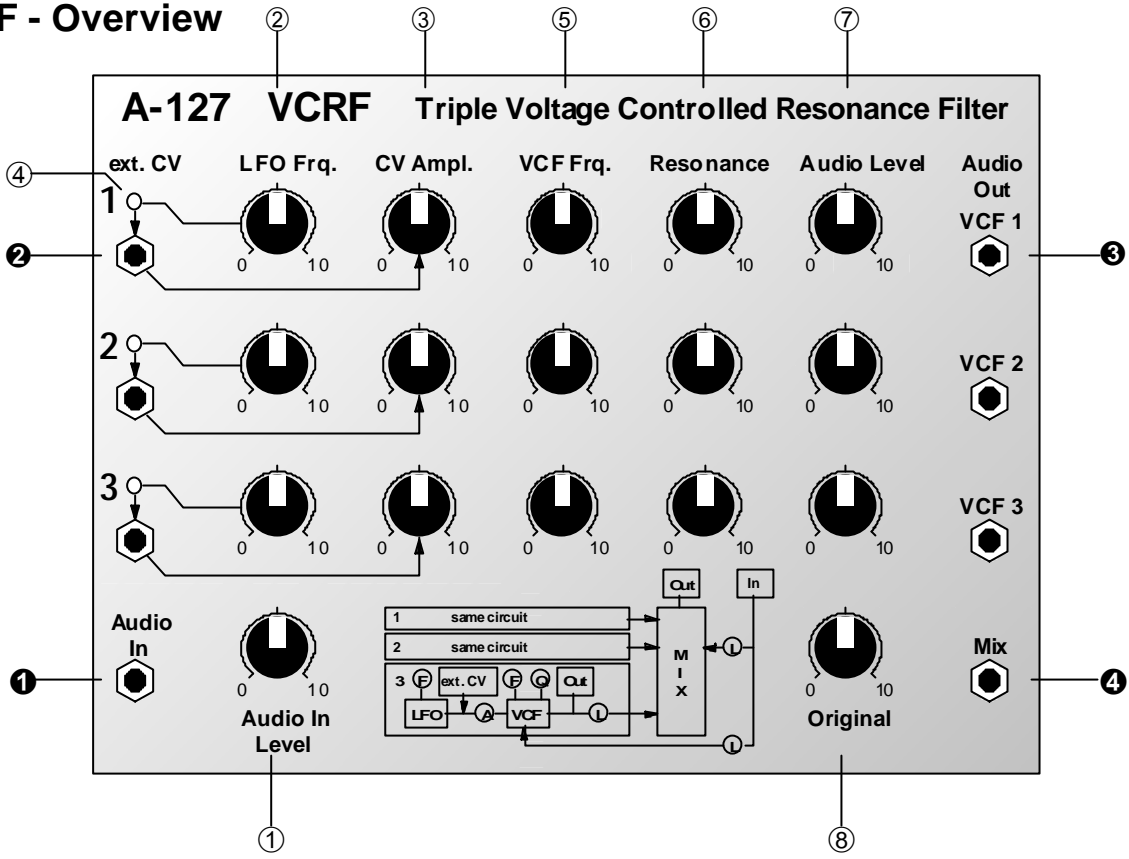

Controls:

- 1 **A. In Level** : Input signal attenuator
- _____ **per VCF:** _____
- 2 **LFO Frq.** : LFO frequency control
- 3 **CV Ampl.** : Attenuator for external CV and/or LFO amplitude
- 4 **LED** : LFO and/or external CV indicator
- 5 **VCF Frq.** : Filter frequency control
- 6 **Resonance** : Filter resonance control
- 7 **Audio Level** : Level control for audio output amplitude of the filter (affecting the individual output § and Mix output \$)

-
- 8 **Original** : Control for setting the amount of the original signal present at the Mix output \$

In- / Outputs:

- ! **Audio In** : Input to the filter
- _____ **per VCF:** _____
- " **ext. CV** : Filter frequency CV input
- § **Audio Out** : Filter output
-
- \$ **Mix Out** : Mix output

3. Basic function

The A-127 is a triple resonant filter containing three band-pass filters each with controllable filter frequency f_M , resonance and amplitude. What a band-pass filter does is to attenuate signals in frequency ranges both above and below the filter frequency - referred to here as the middle frequency - resulting in a bell-shaped response curve (see fig. 1). In this way, a particular part of the audio spectrum can be singled out.

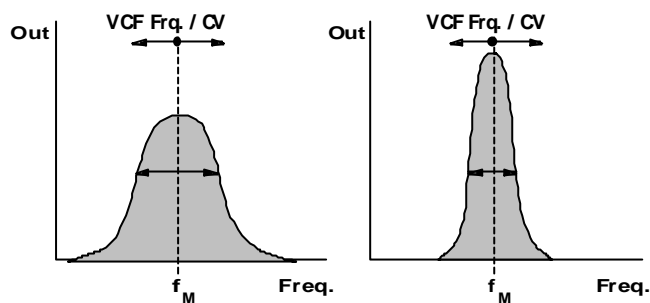

fig. 1: Frequency response of a band-pass filter with lower (on the left) and higher resonance

For each filter you use the frequency control to determine the exact position along the frequency axis, the

resonance control to set the width of the frequency band let through, and the Audio Level control to set the volume (see fig. 1).

To make it easier to understand how the A-127 is configured, fig. 2 shows a block diagram of the internal components.

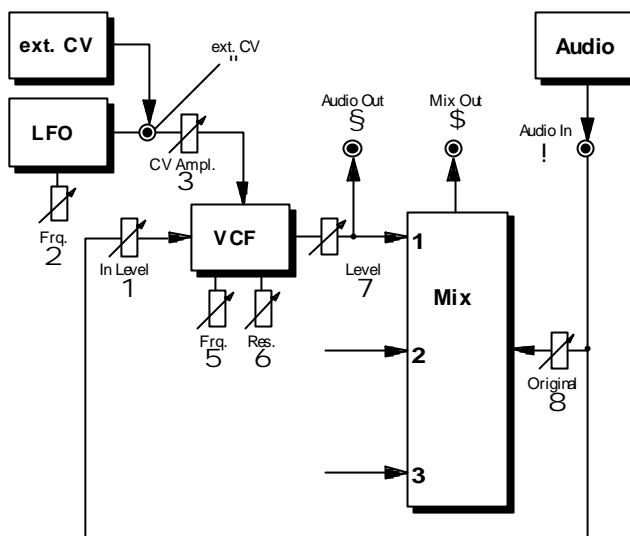

fig. 2: Internal construction of the A-127

4. Controls

1 Audio In Level

With the attenuator 1 you can set the **level** of the audio signals coming in to input ! .

The filter inputs are very sensitive, so it's possible to **overdrive** the Filter with a normal A-100 signal level (e.g. a VCO). With a VCO being input, overdrive starts kicking in at about halfway on the attenuator knob (1)'s travel.

H The module is set up at the factory so that attenuator 1 doesn't have any effect on the Original signal level 8, so the effected sound (3 Filters) and "Original" sound can be controlled separately, by 1 and 8 respectively (see fig. 1). It's possible to change this by altering a jumper on the mixer circuit board (see chapter 7, Appendix), so that both the levels (Filter + Original) can be controlled by attenuator 1 .

2 LFO Frq.

Potentiometer 2 gives control of the **LFO frequency**. The frequency of the LFO's **triangle-wave oscillation**

can be varied from c. 0.02 Hz (oscillation period c. 1 minute) to c. 20 Hz (oscillation period 1/20 sec).

3 CV Ampl.

The **amplitude** of the **modulation signal** is adjusted with attenuator 3, and the source of this modulation depends on whether anything is connected to socket "

If the socket has **nothing connected**, the amplitude of the internal **LFO** is controlled; if the socket does have **something connected**, the amplitude of the **external control voltage** is controlled.

4 LED

LED 4 gives a visual indication of the modulation signal produced by the LFO.

5 VCF Frq.

Control 5 is used to set the **filter frequency f_M** (range: c. 40 Hz to c. 8 kHz).

The actual filter frequency is determined by the sum of the voltages from the control knob and the modulation signal (LFO or external control voltage).

6 Resonance

Control 6 is used to set the **filter resonance**. The higher this control is set, the narrower the **bandwidth** of the bandpass effect (see fig. 1).

If the module has been re-configured to be a **low pass filter**, control 6 boosts the frequencies around the filter cut-off point (see also the A-120 and A-122 low pass filter modules). Using the filter at high resonance to produce its own pitched tone (self-oscillation) isn't possible with this module.

7 Audio Level

Attenuator 7 adjusts the **amount of the signal** from each of the filters to be fed into the **Mix signal** at output 5.

8 Original

Whatever original signal was present at socket 1 can also be added into the internal mixer. The **amount** of the original signal fed into the **mix output signal** is set by attenuator 8.

H The module is set up at the factory so that attenuator 1 doesn't have any effect on the Original signal level 8, so the effected sound (3 Filters) and "Original" sound can be controlled separately, by 1 and 8 respectively (see fig. 1). It's possible to change this by altering a jumper on the mixer circuit board (see chapter 7, Appendix), so that both the levels (Filter + Original) can be controlled by attenuator 1.

5. In- / Outputs

! Audio In

This is the socket into which you connect the **audio signal which you want to be filtered**.

" ext. CV

Socket " is the **control voltage input**, used for modulating the filter via external voltage control (ADSR, LFO, sequencer - see chapter 7, User Examples).

This is a **normalised (switched) socket**. If no connection is made, the **internal LFO** serves as the modulation source instead.

§ Audio Out

Each **filter Audio output** § sends out the signal processed by the particular filter. Despite what the diagram on some of the early A-127 modules shows, the Audio Level control 7 does also affect these individual outputs, because the individual output comes after the Audio Level control in the circuit.

\$ Mix

At socket \$ the **mixed output** from the internal mixer is available. That includes the output from each of the three filters (with level from each filter set by control 7) and the original signal (with level set by control 8).

6. User examples

By controlling filter frequencies with the internal LFO or external voltages, the A-127 can produce extremely complex filtering effects.

The control possibilities available with **external Modulation sources** are almost limitless.

Here are just a few examples:-

- **LFO**
other waveforms - not just triangle; LFO frequencies in the Audio- range
- **ADSR**
different envelopes for each of the individual filters; complex filter sweeps
- **MIDI Interface A-191**
different MIDI controllers for each of the individual filters: MIDI-controlled vowel sounds (see Examples below)
- **Random-CV A-118**
random filter settings

- **Theremin A-178**
filter settings by remote control!
- **Sequencer A-155 or MAQ 16/3**
vocoder- and speech-like effects with specially shaped external CV sequences (see below)
- **S&H filter effects with an A-148**
the A-148 Sample&Hold samples signals from modulation sources (LFO, Noise, Random, VCO, etc.) at regular clock intervals (see fig. 3)

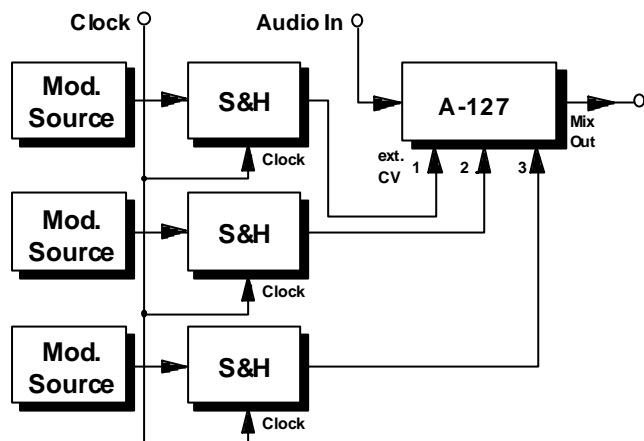

fig. 3: S&H filter effects with an A-148

One of the A-127's particular strengths is its ability to bring out the **formants** that are crucial in re-creating some sounds. It's able to latch on to particular frequencies or ranges of frequencies which are characteristic of an instrument, a room, or an acoustic effect, and emphasise them within the whole frequency spectrum.

Equalisation is often used to suppress these formants when a room's acoustics need to be neutralised; but the A-127 can actually work the other way, to simulate a real room's formants, and bring a sound alive.

A special application of this ability to build up formants can be to simulate human speech - or more exactly, **human vowel sounds**.

What happens when a person pronounces a vowel is that the overtone-rich vocal cord sound sets off all sorts of resonances in the mouth, nose and throat, whose frequency depends mostly on the shape of the mouth and position of the tongue.

The characteristic sound of each vowel is created by formants - ranges of frequencies emphasised by the mouth and throat creating resonant cavities which pick out harmonics from the basic sound of the vocal cords.

The most important frequencies for formants in German vowel sounds is shown in fig. 4.

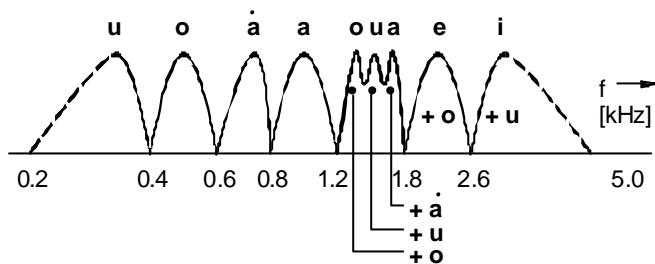

fig. 4: German vowel formant frequency range.

In the patch in fig. 5, this process is simulated by two of the A-127's band-pass filters, with the sawtooth output from a VCO acting as the sound source. An A-155 sequencer controls the A-127. Pitch is controlled by a keyboard.

The resonance of both of the band-pass filters should be set quite high. The sounds from this patch will be more realistic if the individual sounds slide from one to the next (using the Glide Control on the A-155).

P It's also possible to use **non-harmonic** sound spectra (e.g. ring modulator signals) for further experimentation.

Another source for discovering the formant frequency range of English language vowel sounds is Allen Strange's book *Electronic Music*. Here, he specifies three centre frequencies for the formants for each of the vowel sounds (see Table 1).

Band	ee	i	e	ae	ah	aw	u	oo	A	er
1	270	390	530	660	730	570	440	300	640	490
2	1990	1840	1720	1090	1840	1020	870	1190	1350	-
3	3010	2550	2480	2410	2440	2410	2240	2240	2390	1690

Tab. 1: Band-pass filter frequencies 1 to 3 for the production of male vowel sounds (from: Allen Strange, "Electronic Music")

If you're trying out the patch in fig. 5, then just use the first two frequency settings in each set of three.

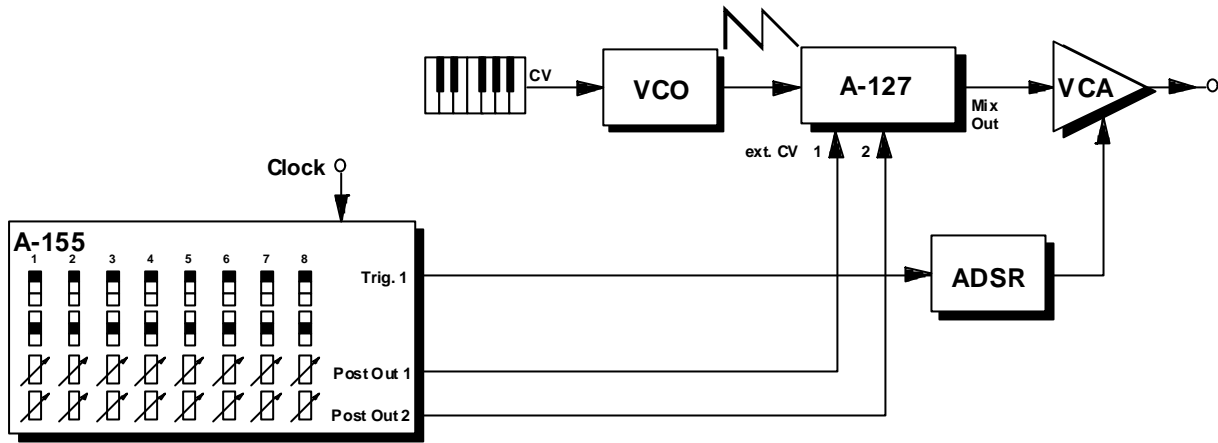

fig. 5: Simulation of vowel sounds

Otherwise, three vowel formant frequencies can be produced using either a MAQ 16/3 sequencer, with three control voltages per step, or by running two A-155 sequencers in parallel. In this case, you could use the spare CV from the second A-155 for pitch control (instead of an external keyboard) or to produce different decay times, by using a VC-ADSR instead of a standard ADSR.

6. Patch-Sheet

The following diagram of the module can help you recall your own **Patches**. It's designed so that a complete 19" rack of modules will fit onto an A4 sheet of paper.

Photocopy this page, and cut out the pictures of this and your other modules. You can then stick them onto another piece of paper, and create a diagram of your own system.

Make multiple copies of your composite diagram, and use them for remembering good patches and set-ups.

- P
- Draw in patchleads with colored pens.
 - Draw or write control settings in the little white circles.

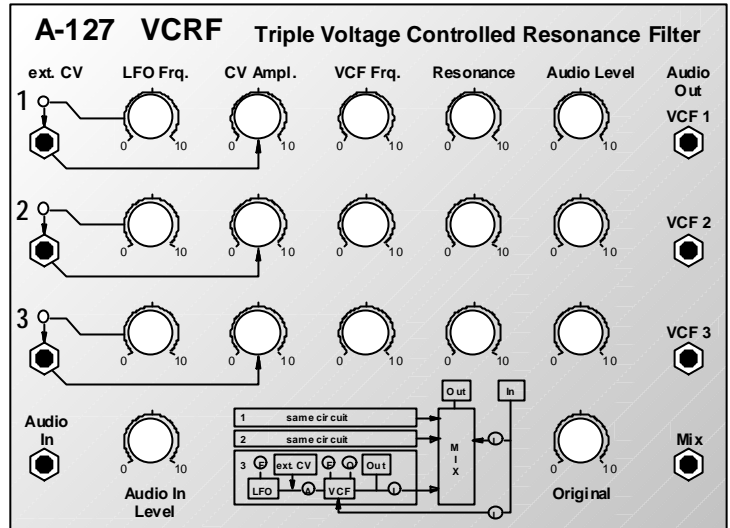

7. Appendix

Altering the filter characteristics

The **characteristics** of each of the individual filters in the A-127 can be altered by changing the position of the **jumper J1** on its three-pin connector on the filter circuit-board (see fig. 6).

The standard factory setting is for each of the filters to be set to the bandpass position (labelled "BP").

You can, if you want, alter the response of each **individual filter**, so that it is **12 db low-pass**.

To do this, change **Jumper J1** on the circuit board from position "BP" to **position "LP"** (low pass) - see Fig. 6.

Changing how control 1 works

As standard from the factory, Attenuator 1 doesn't have any effect on the Original control 8, so that it's possible to adjust 1 and 8 independently.

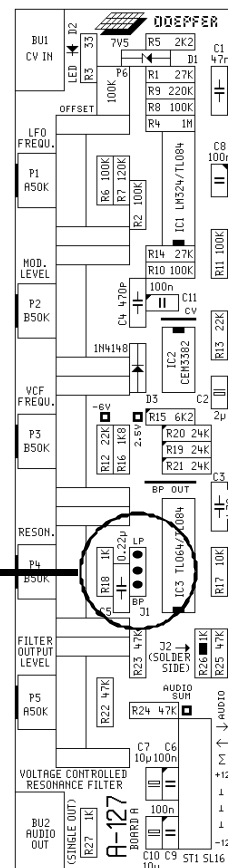
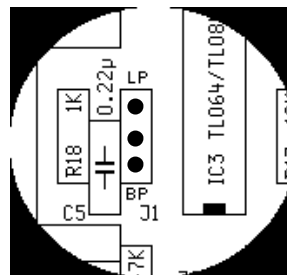

fig. 6: A-127 filter circuit-board

To change this, you can alter the position of **Jumper J3** on the **Mix circuit-board** from "Pre" (the factory default) to "Post" (see fig. 8). In this case, control 1 comes before the Original signal level control 8, and so does affect both the filter and Original signals.

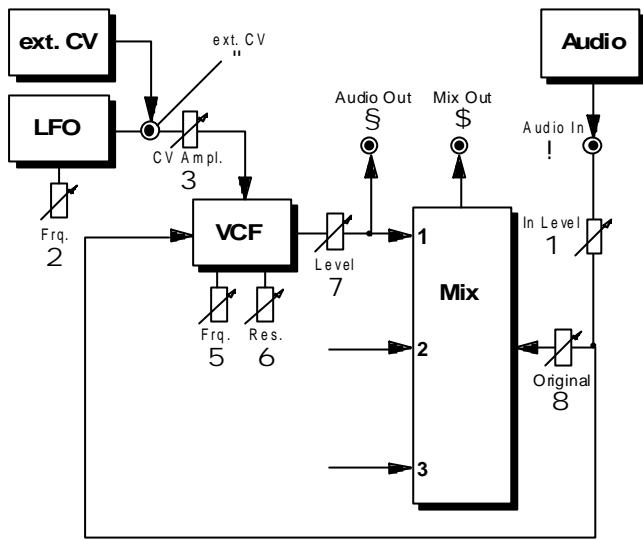

fig. 7: A-127 signal path with jumper set to "post"

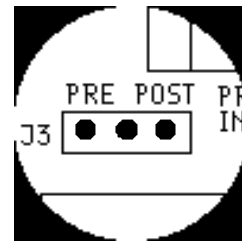

fig. 8: A-127 mix circuit-board

